

M-200D

200 GPM OF TRUE CLEANING CAPACITY



Power Train

Generator Set: Gen-Tech 90kW is standard

Fuel Capacity: 55 U.S. gal (208 L)

Operating Controls

Pendant for offload (supercharge) start/stop

Pit pump pendant/control start/stop

Mud Pumps

Centrifugal Pumps: 250 series with mechanical seal and 25 HP motors

Cone Supply & Agitation: 3 in x 4 in with 10.5 in Impeller

Mud Mix & Agitation: 3 in x 4 in with 10.5 in Impeller

Offload & Agitation: 3 in x 4 in with 9 in Impeller

Bentonite Mixer: Polyethylene dry bentonite mix hopper



MUD CLEANING SYSTEM



Cleaning System

Derrick® FLC-503™ Linear Motion Shaker (1): 3 panel with 34.5 ft² non-blank screen area

Shaker Screens Included: (1) API 60 Derrick PMD+ (pyramid plus)
(1) API 50 Derrick PMD+ (pyramid plus)
(1) API 140 Derrick PMD+ (pyramid plus)

1st Cut Shaker Cleaning Capacity: up to 200 U.S. gal. (760 L)/min

Desilting Cones: (5) 5 in (127 mm) desilter hydrocyclones

Desilting Capacity: up to 600 U.S. gal. (2,271 L)/min

Tanks

Total Tank Capacity: 3,000 U.S. gal (11,356 L)

Screen Tank: 1,700 U.S. gal (6,435 L)

Clean Fluid/Mixing Tank: 1,300 U.S. gal (4,921 L)

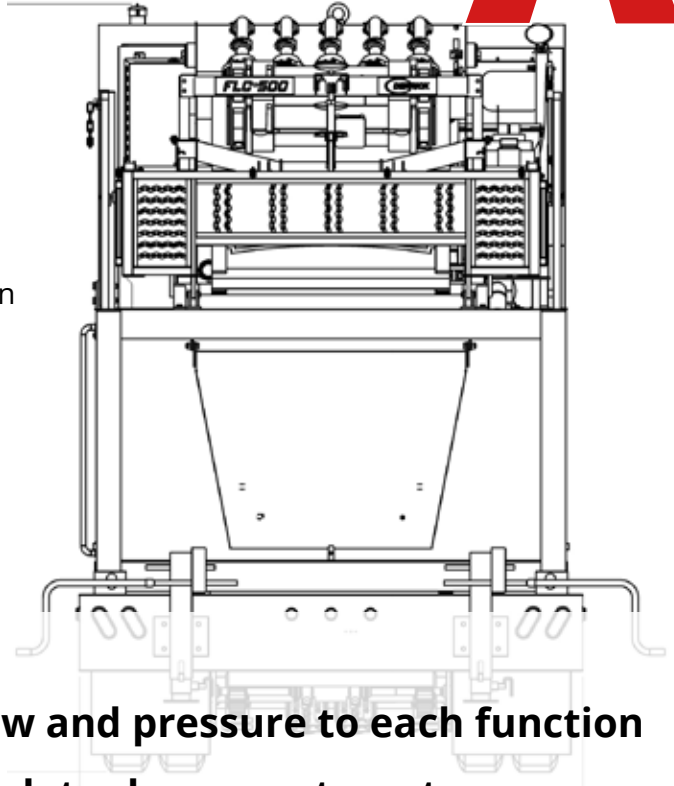

- Packaged to fit on low space jobsites
- 3 dedicated centrifugal pumps to ensure flow and pressure to each function
- Tank agitation prevents solids settling in each tank compartment
- Trailer or skid mounted units gives flexibility
- Compatible with any drill brand



Dimensions/Weights

Length:	20 ft (6.1 m) without trailer	26.2 ft (7.98 m) with trailer
Height:	10 ft (3.05 m) without trailer	13 ft (3.96 m) with trailer
Width:	8 ft (2.44 m) with or without trailer	
Total Weight:	21,000 lbs without trailer	27,600 lbs with trailer